

Front view of Sepam.

Dimensions

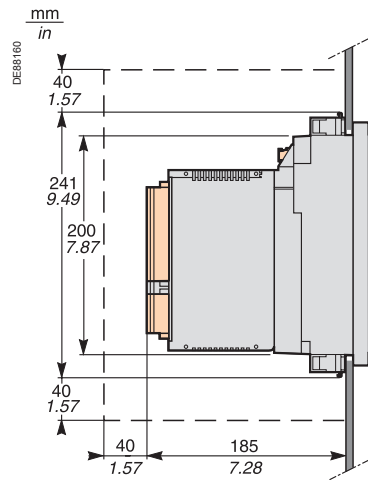

Side view of Sepam with MES120, flush-mounted in front panel with spring clips.
Front panel: 1.5 mm (0.05 in) to 6 mm (0.23 in) thick.

--- Clearance for Sepam assembly and wiring.

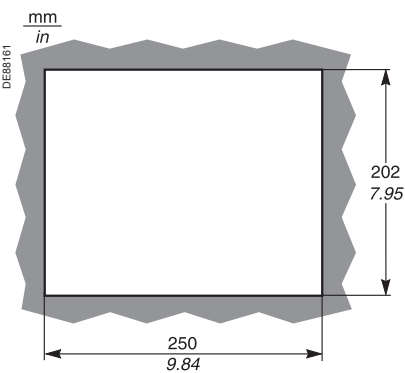

Cut-out.

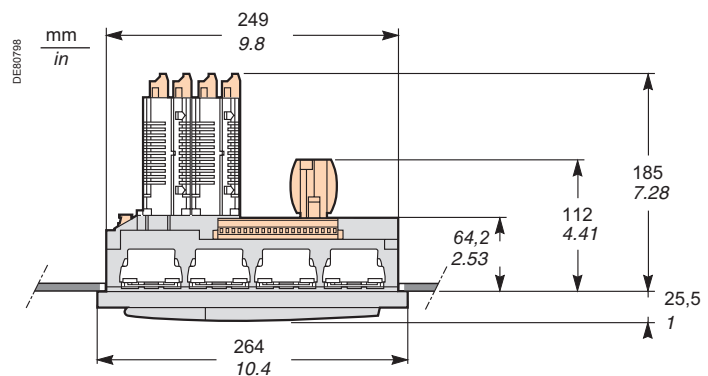

Top view of Sepam with MES120, flush-mounted in front panel with spring clips.
Front panel: 1.5 mm (0.05 in) to 6 mm (0.23 in) thick.

CAUTION

HAZARD OF CUTS

Trim the edges of the cut-out plates to remove any jagged edges.

Failure to follow this instruction can cause serious injury.

Assembly with AMT880 mounting plate

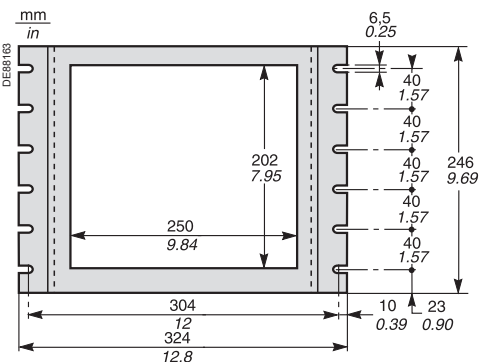

AMT880 mounting plate.

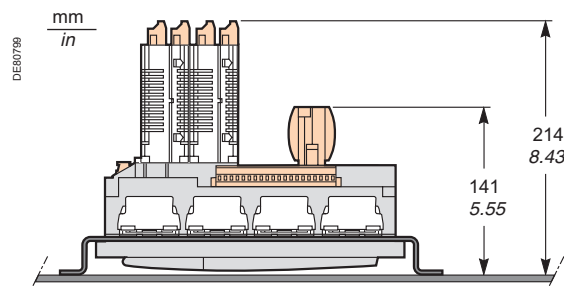

Top view of Sepam with MES120, mounted with AMT880 and spring clips.
Mounting plate: 3 mm (0.11 in) thick.

